

1000-MHz Quadrature Modulator

Description

The IC U2797B is a 1000-MHz quadrature modulator that uses TELEFUNKEN's advanced UHF process. It features a frequency range from 100 MHz up to 1000 MHz, low current consumption, and single-ended RF and LO ports.

The I/Q input impedance is about 150 k Ω . Adjustment free application makes the direct converter suitable for all digital radio systems up to 1000 MHz, e.g., GSM, DAMPS, PDC.

Features

- Supply voltage: 5 V (typical)
- Low power consumption: 30 mA/5 V (typical at -1 dBm output level)
- 150 k Ω I/Q input impedance
- Excellent sideband suppression by means of duty cycle regeneration of the LO input signal
- Phase control loop for precise 90° phase shifting
- Power down mode
- Low LO input level: -10 dBm (typical)

- 50- Ω single-ended LO and RF port
- LO- frequency range of 100 MHz to 1 GHz
- SSO 20 package

Benefits

- Extended talk time due to increased battery life
- Few external components result in cost and board space saving
- Adjustment-free hence saves time

Block Diagram

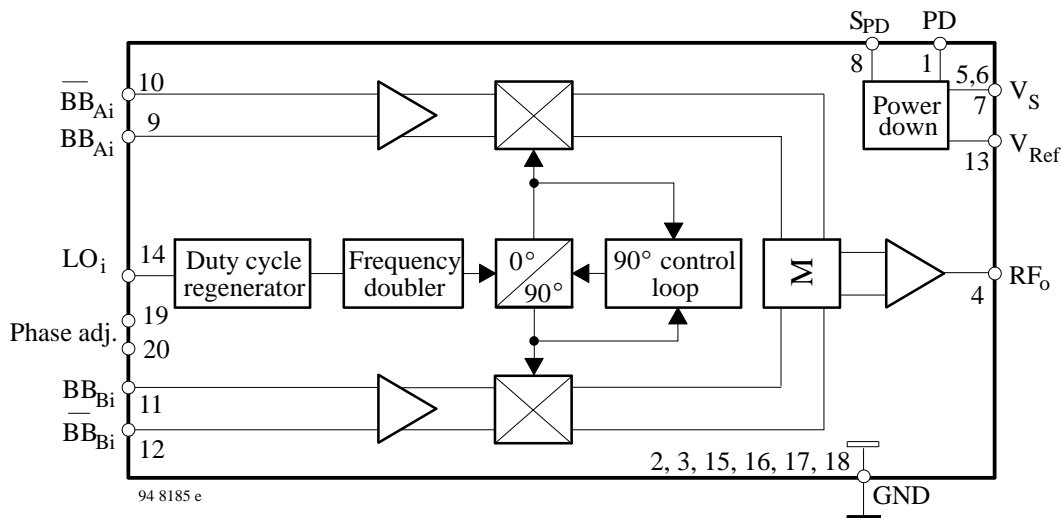

Ordering Information

Extended Type Number	Package	Remarks
U2797B-AFS	SSO20	Rail, MOQ 830 pcs.
U2797B-AFSG3	SSO20	Tape & reel, MOQ 4000 pcs.

Pin Description

SSO 20

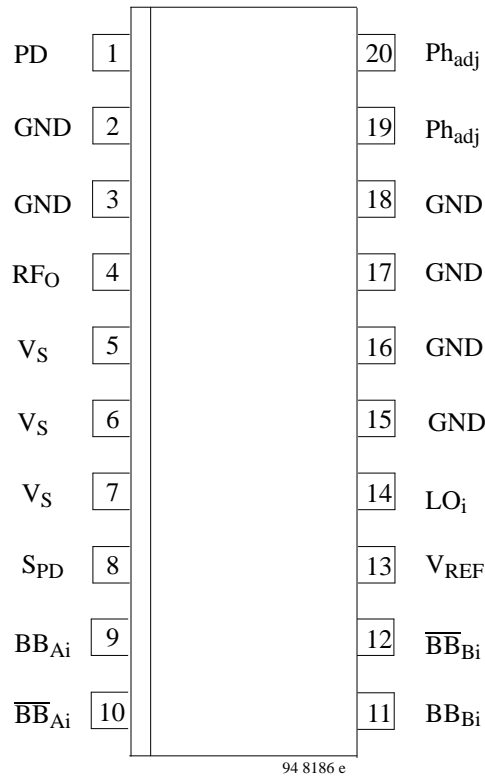

U2790B-FS (SSO 20)

Pin	Symbol	Function
1	PD	Power down port
2	GND	Ground
3	GND	Ground
4	RF _o	RF output
5	V _S	Supply voltage
6	V _S	Supply voltage
7	V _S	Supply voltage
8	S _{PD}	Settling time power down
9	BB _{Ai}	Baseband input A
10	$\overline{\text{BB}}_{\text{Ai}}$	Baseband input A inverse
11	BB _{Bi}	Baseband input B
12	$\overline{\text{BB}}_{\text{Bi}}$	Baseband input B inverse
13	V _{REF}	Reference voltage (2.5 V)
14	LO _i	LO input
15	GND	Ground
16	GND	Ground
17	GND	Ground
18	GND	Ground
19/20	Ph _{adj}	Phase adjustment (not necessary for regular applications)

Absolute Maximum Ratings

Parameters	Symbol	Value	Unit
Supply voltage Pins 5, 6 and 7	V _S	6	V
Input voltage Pins 9, 10, 11, 12, 14 and 15	V _i	0 to V _S	V
Junction temperature	T _j	125	°C
Storage temperature range	T _{stg}	-40 to +125	°C

Operating Range

Parameters	Symbol	Value	Unit
Supply voltage range Pins 5, 6 and 7	V _S	4.5 to 5.5	V
Ambient temperature range	T _{amb}	-40 to +85	°C

Thermal Resistance

Parameters	Symbol	Value	Unit
Junction ambient SSO 20	R _{thja}	140	K/W

Electrical characteristics

Test conditions (unless otherwise specified): $V_S = 5\text{ V}$, $T_{\text{amb}} = 25^\circ\text{C}$, referred to test circuit. System impedance $Z_O = 50\ \Omega$, $f_{\text{LO}} = 900\text{ MHz}$, $P_{\text{LO}} = -10\text{ dBm}$, $V_{\text{BBi}} = 1\text{ V}_{\text{pp}}$ diff

Parameters	Test conditions / Pin	Symbol	Min.	Typ.	Max.	Unit
Supply voltage range	Pins 5, 6 and 7	V_S	4.5		5.5	V
Supply current	Pins 5, 6 and 7	I_S		30		mA
Baseband inputs		Pins 9-10, 11-12				
Input voltage range (differential)		V_{BBi}		1000	1500	mV _{pp}
Input impedance (single ended)		Z_{BBi}		150		k Ω
Input frequency range		f_{BBi}	0		200	MHz
LO input		Pin 14				
Frequency range		f_{LOi}	100		1000	MHz
Input level ¹		P_{LOi}	-12	-10	-5	dBm
Input impedance		Z_{iLO}		50		Ω
Voltage standing wave ratio		VSWR_{LO}		1.4	2	-
Duty cycle range		DCR_{LO}	0.4		0.6	-
RF output		Pin 4				
Output level		P_{RFo}	-5	-1		dBm
LO suppression ²	$f_{\text{LO}} = 900\text{ MHz}$ $f_{\text{LO}} = 150\text{ MHz}$	LO_{RFo}	30 32	35 35		dB
Sideband suppression ^{2,3}	$f_{\text{LO}} = 900\text{ MHz}$ $f_{\text{LO}} = 150\text{ MHz}$	SBS_{RFo}	35 30	40 35		dB
Phase error ⁴		P_e		< 1		deg.
Amplitude error		A_e		< ± 0.25		dB
Noise floor	$V_{\text{BBi}} = 2\text{ V}$, $\overline{V_{\text{BBi}}} = 3\text{ V}$ $V_{\text{BBi}} = \overline{V_{\text{BBi}}} = 2.5\text{ V}$	N_{FL}		-132 -144		dBm/Hz
VSWR		VSWR_{RF}		1.6	2	
3rd order baseband harmonic suppression		S_{BBH}	35	45		dB
RF harmonic suppression		S_{RFH}		35		dB
Power down mode						
Supply current	$V_{\text{PD}} \leq 0.5\text{ V}$ Pins 4, 5 $V_{\text{PD}} = 1\text{ V}$	I_{PD}		10	1	μA
Settling time	$C_{\text{SPD}} = 100\text{ pF}$ $C_{\text{LO}} = 100\text{ pF}$ $C_{\text{RFo}} = 1\text{ nF}$ Pin 6 to 3	t_{sPD}		10		μs
Switching voltage		Pin 1				
Power on		V_{PDon}	4			V
Power down		V_{PDdown}			1	V
Reference voltage		Pin 13				
Voltage range		V_{Ref}	2.35	2.5	2.65	V
Output impedance		$Z_{\text{o Ref}}$		30		Ω

Note: 1 The required LO level is a function of the LO frequency

Note: 2 In reference to a RF output level $\leq -1\text{ dBm}$ and I/Q input level of $400\text{ mV}_{\text{pp}}$ diff.

Note: 3 Sideband suppression is tested without connection at pins 19 and 20. For higher requirements a potentiometer can be connected at these pins.

Note: 4 For $T_{\text{amb}} = -40\text{ to }+85^\circ\text{C}$ and $V_S = 4.5\text{ to }5.5\text{ V}$

Typical single sideband output spectrum

$f_{LO} = 900 \text{ MHz}$, $P_{LO} = -10 \text{ dBm}$, $V_{BBI} = 1 \text{ V}_{PP}$ (differential), $T_{amb} = 25^\circ\text{C}$

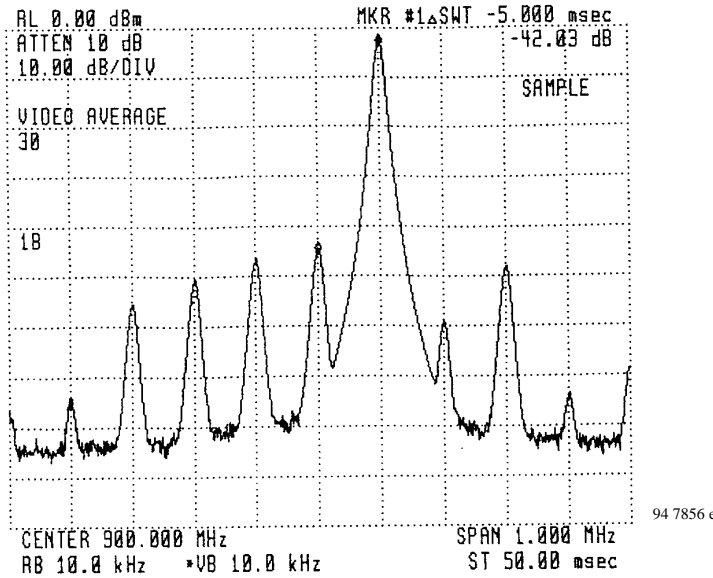

Typical GMSK output spectrum

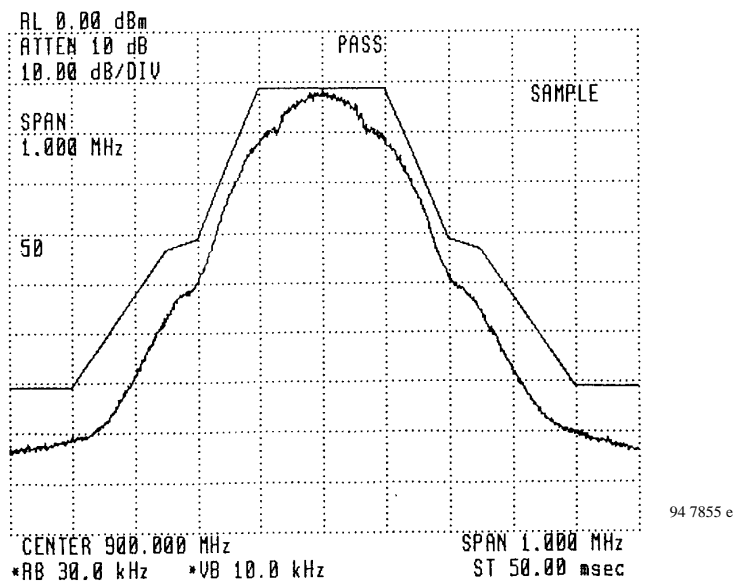

Typical RF-harmonic output spectrum

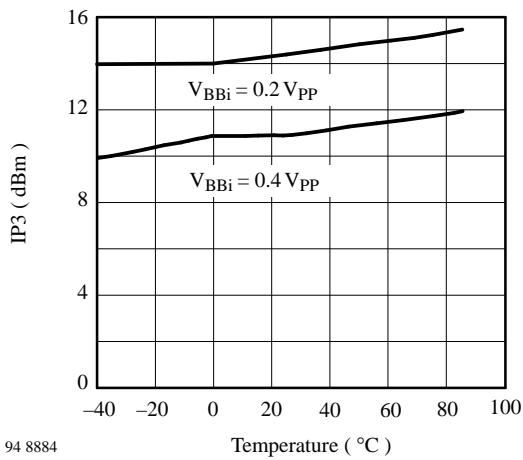
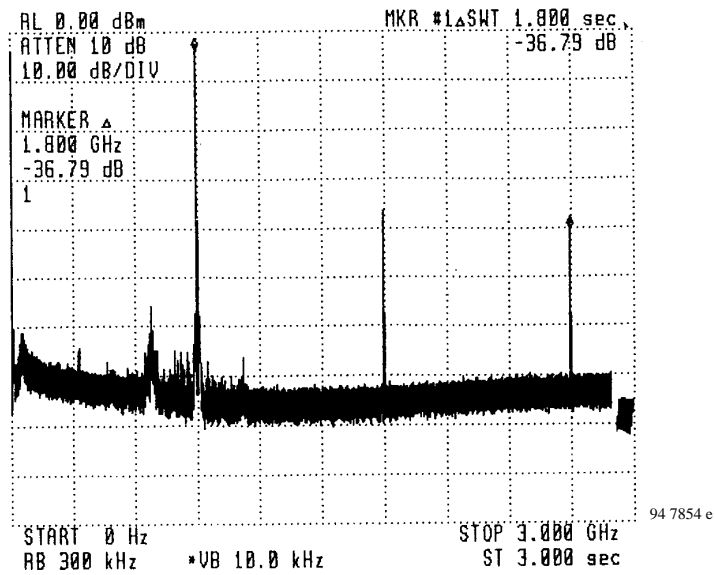

OIP3 vs. T_{amb} , LO = 150 MHz, level - 20 dBm

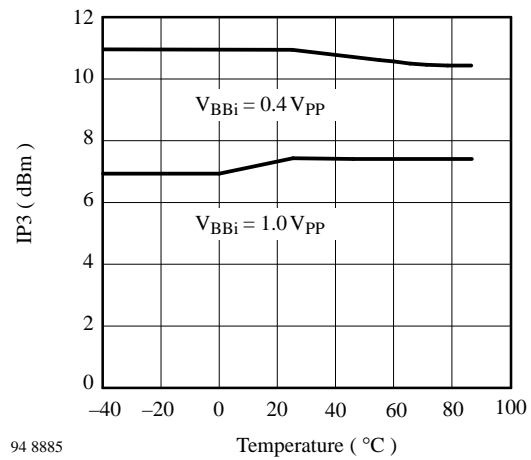

OIP3 vs. T_{amb} , LO = 900 MHz, level - 10 dBm

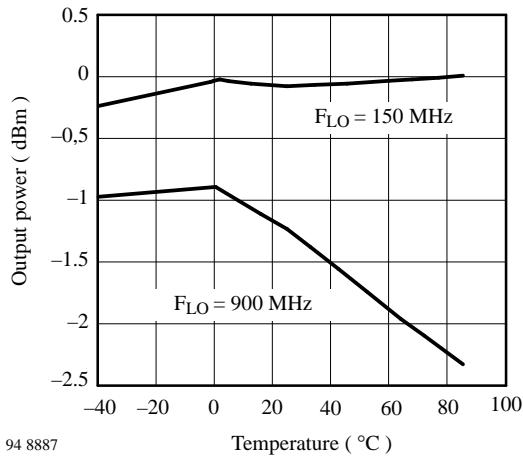

Output power vs. T_{amb}

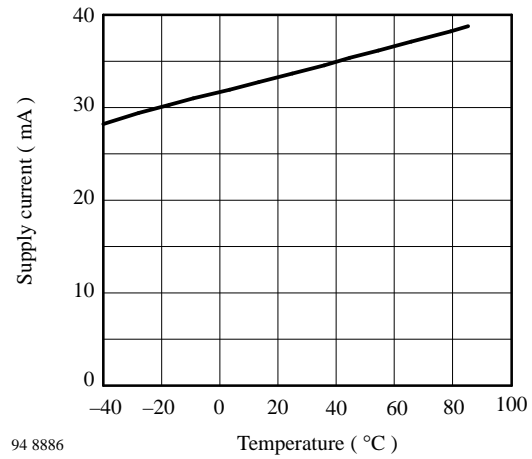

Supply current vs. T_{amb}

Typical S11 frequency response of the RF output

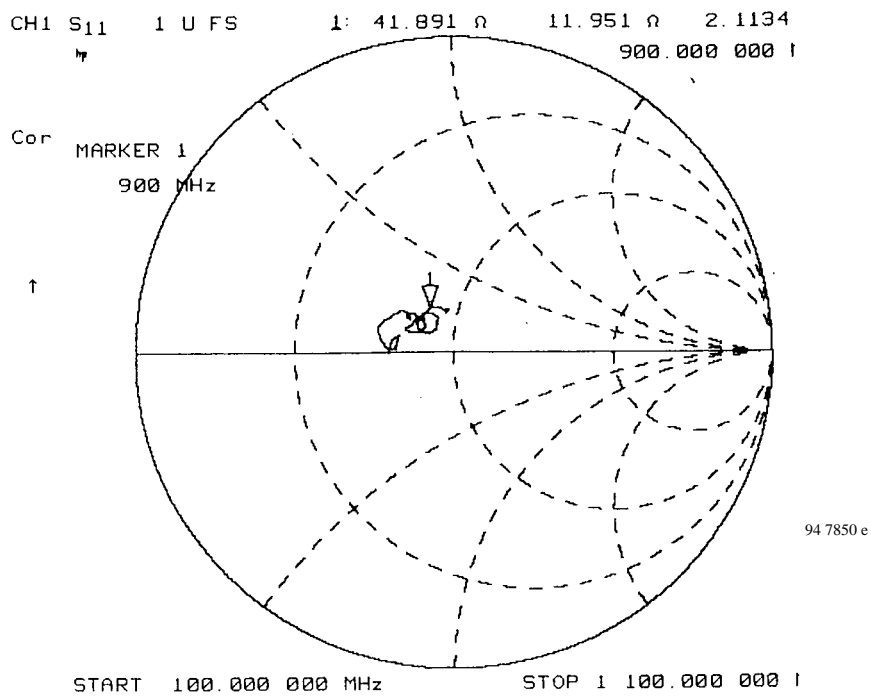

Typical VSWR frequency response of the RF output

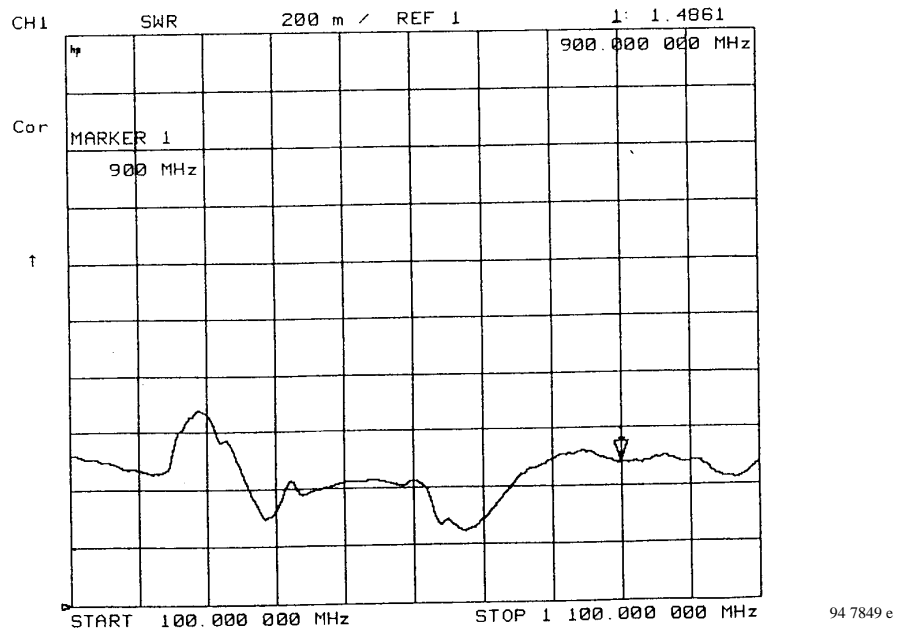

Typical S11 frequency response of the LO input

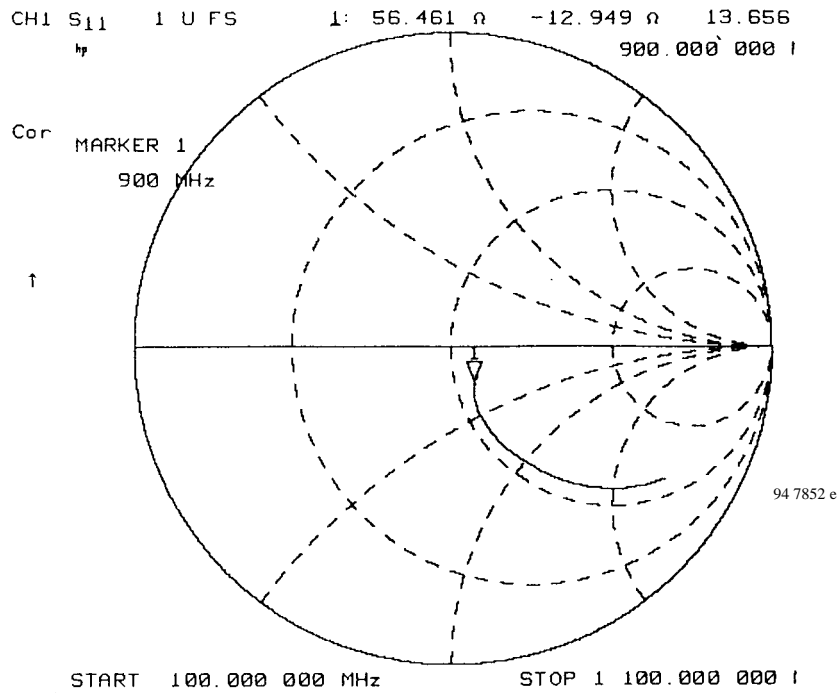

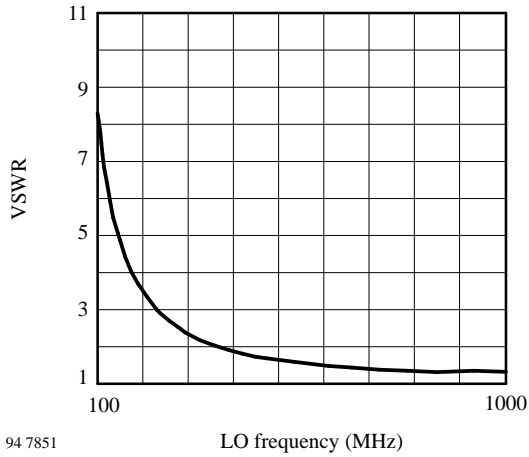

Typical VSWR frequency Response of the LO Input

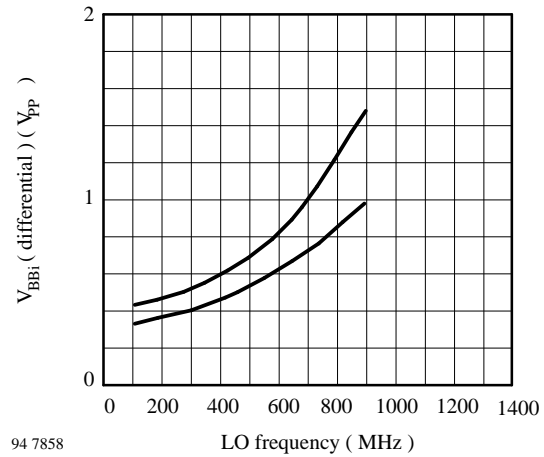

Typical Required V_{BBi} Input Signal (differential) vs. LO Frequency for $P_O = 0$ dBm and $P_O = -2$ dBm

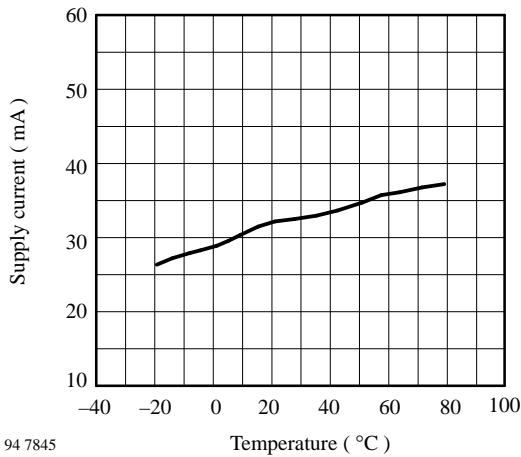

Typical supply current vs. temperature at $V_S = 5$ V

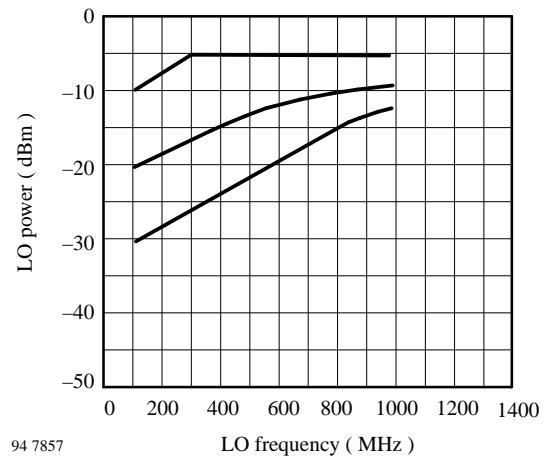

Typical useful LO power range vs. LO frequency at $T_{amb} = 25^\circ\text{C}$

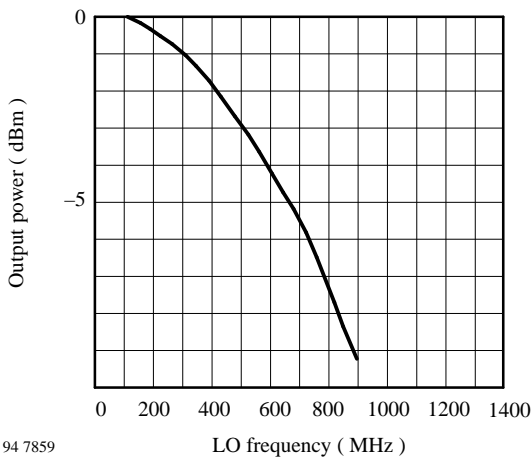

Typical output power vs. LO-frequency at $T_{amb} = 25^\circ\text{C}$, $V_{BBi} = 230$ mV_{PP} (differential)

Application circuit

Bias network for ac coupled baseband inputs (V_{BA} , V_{BB}).

$R_1 = 2.5 \text{ k}\Omega$, $R_2 \cong 10 \text{ k}\Omega$ for $\leq 35 \text{ dB}$ LO suppression which is in reference to $< 2 \text{ mV}$ input offset.

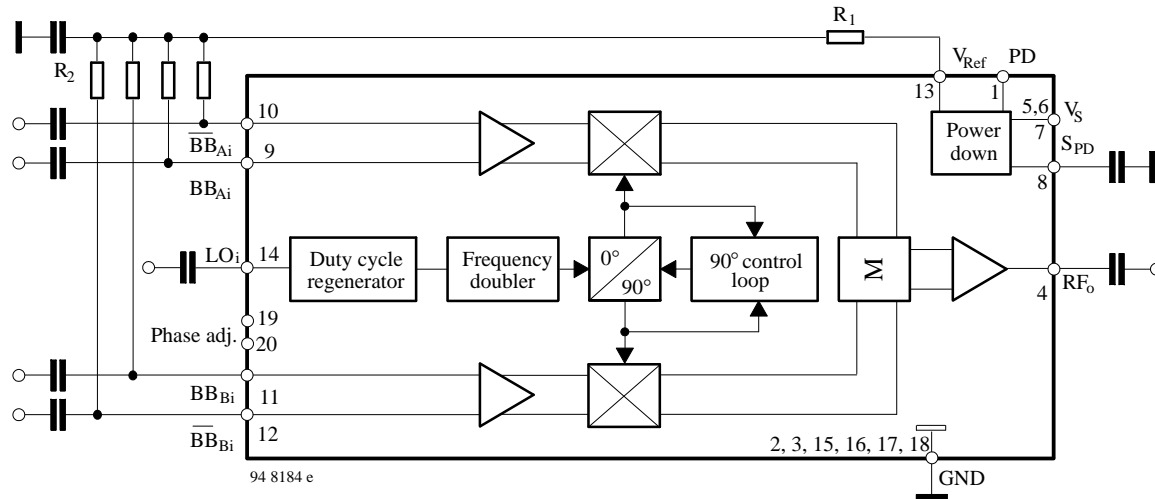

PCB layout

U2797B-FS (SSO 20)

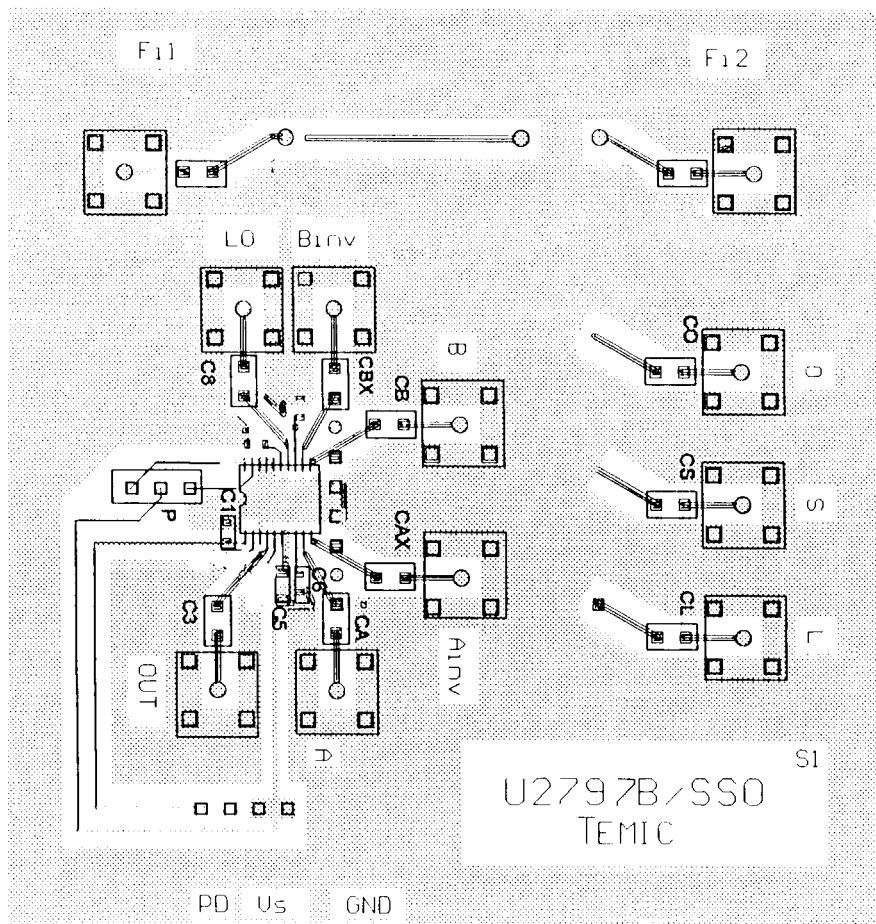

Evaluation circuit (PCB equip)

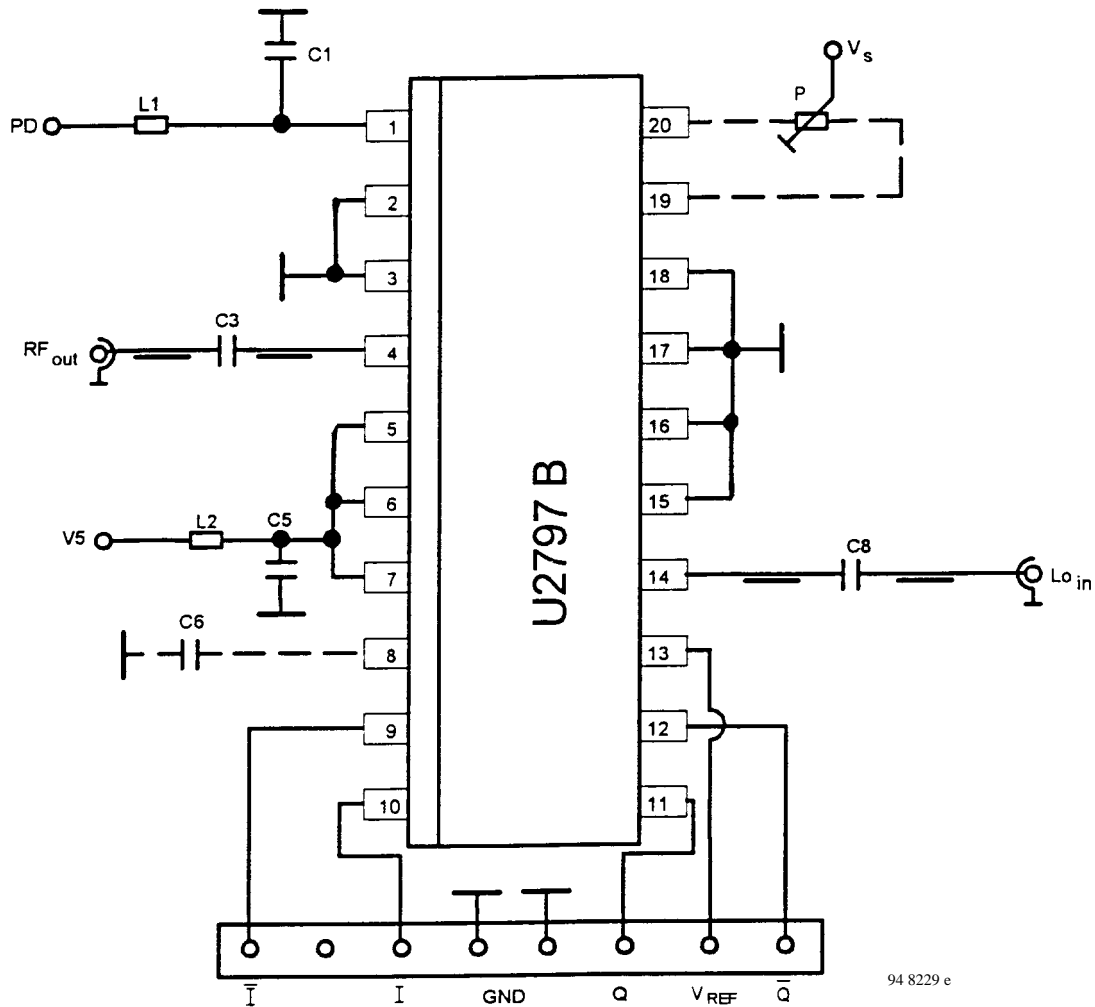

94 8229 e

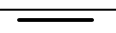
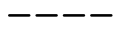
Part list	
C1, C3, C6	1 nF
C8	100 pF
C5	100 nF
P	Poti 10 kΩ
L1, L2	PCB Inductor
	50 Ω Microstrip
	optional

The above listed components result in a PD settling time of $< 20 \mu\text{s}$.
Use of other component values will require consideration of time requirements in burst-mode applications.

Application notes

1. Noise floor and settling time

In order to reduce noise on the power down control input and improve the wide-off noise floor of the 900-MHz RF output signal, capacitor C_{PD} should be connected from pin 8 to ground in the shortest possible way.

The settling time has to be considered for the system under design. For GSM applications a value of $C_{PD} = 1 \mu\text{F}$ defines a settling time, t_{sPD} , equal or less than $3 \mu\text{s}$. This capacitance does not have any influence on the noise floor within the relevant GSM mask. For mobile application

the mask requirements can be achieved very easily without C_{PD} .

A significant improvement of the wide-off noise floor is obtainable with C_{PD} greater than 100 nF. Such values are recommended for applications where the settling time is not critical, such as in base stations. Coupling capacitors for LO_i and RF_O also have a certain impact on the settling time. The values used for the measurements are $C_{LOi} = 100 \text{ pF}$ and $C_{RFo} = 1 \text{ nF}$.

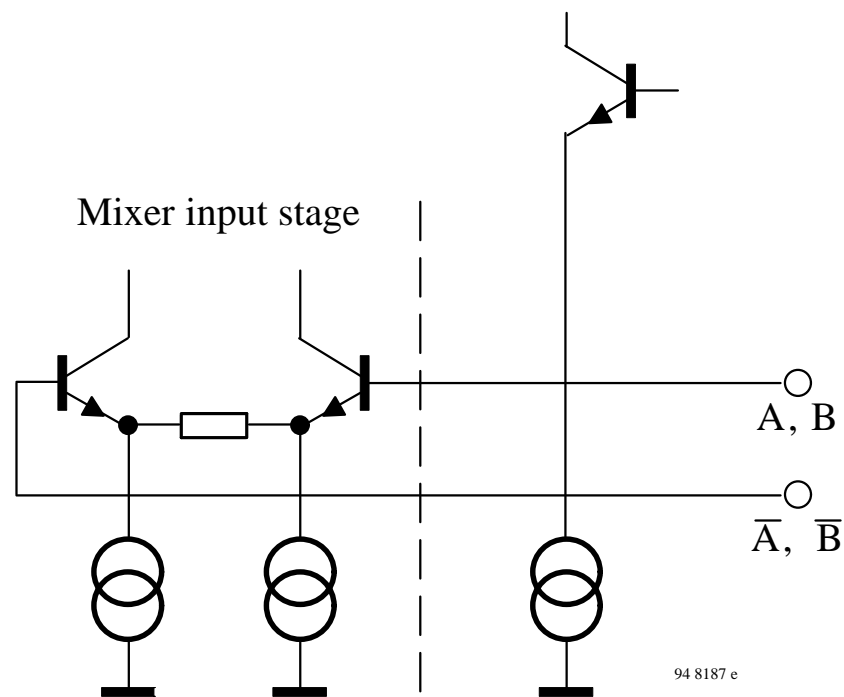

Figure 1 baseband input circuitry

U2797B-FS (SSO 20) has a $150 \text{ k}\Omega$ baseband input impedance. The reference voltage, V_{REF} , is provided at pin 13.

Ozone Depleting Substances Policy Statement

It is the policy of **TEMIC TELEFUNKEN microelectronic GmbH** to

1. Meet all present and future national and international statutory requirements.
2. Regularly and continuously improve the performance of our products, processes, distribution and operating systems with respect to their impact on the health and safety of our employees and the public, as well as their impact on the environment.

It is particular concern to control or eliminate releases of those substances into the atmosphere which are known as ozone depleting substances (ODSs).

The Montreal Protocol (1987) and its London Amendments (1990) intend to severely restrict the use of ODSs and forbid their use within the next ten years. Various national and international initiatives are pressing for an earlier ban on these substances.

TEMIC TELEFUNKEN microelectronic GmbH semiconductor division has been able to use its policy of continuous improvements to eliminate the use of ODSs listed in the following documents.

1. Annex A, B and list of transitional substances of the Montreal Protocol and the London Amendments respectively
2. Class I and II ozone depleting substances in the Clean Air Act Amendments of 1990 by the Environmental Protection Agency (EPA) in the USA
3. Council Decision 88/540/EEC and 91/690/EEC Annex A, B and C (transitional substances) respectively.

TEMIC can certify that our semiconductors are not manufactured with ozone depleting substances and do not contain such substances.

We reserve the right to make changes to improve technical design and may do so without further notice.

Parameters can vary in different applications. All operating parameters must be validated for each customer application by the customer. Should the buyer use TEMIC products for any unintended or unauthorized application, the buyer shall indemnify TEMIC against all claims, costs, damages, and expenses, arising out of, directly or indirectly, any claim of personal damage, injury or death associated with such unintended or unauthorized use.

TEMIC TELEFUNKEN microelectronic GmbH, P.O.B. 3535, D-74025 Heilbronn, Germany
Telephone: 49 (0)7131 67 2831, Fax number: 49 (0)7131 67 2423